

4016 Series Door Closer INSTALLATION INSTRUCTIONS



Sentinel Door Controls, LLC

Phone 1.800.327.7848
Fax 1.888.412.3667

sales@sentineldoor.com
estimating@sentineldoor.com
www.sentineldoor.com

Non-Hold open Adjustable power size 1 thru 6

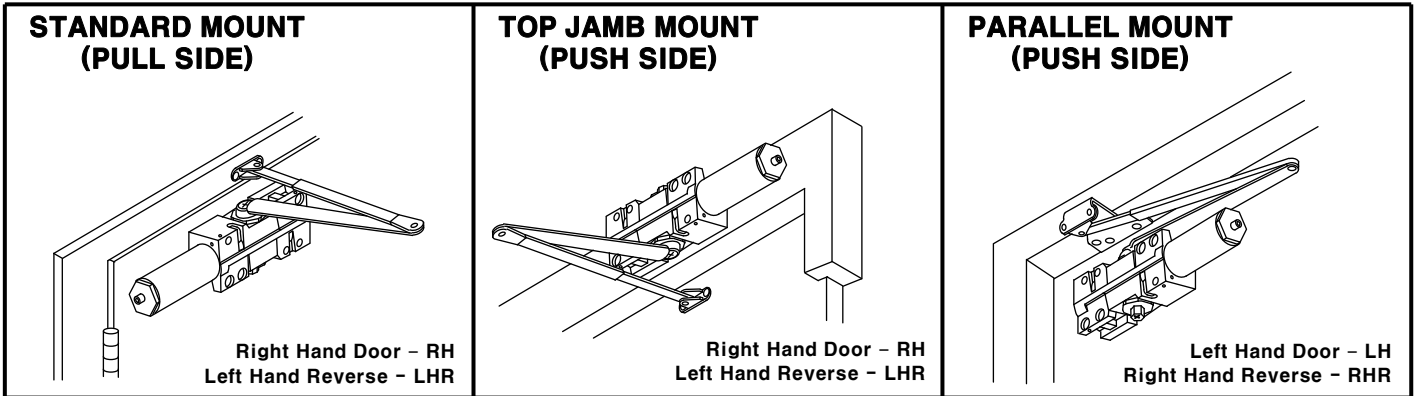

DOOR CLOSER SIZE	MAXIMUM DOOR WIDTH		FULL TURNS OF POWER ADJUSTMENT SCREW
	EXTERIOR (SWING OUT)	INTERIOR	
1	28"(0.71m)	32"(0.81m)	7C.C.W
2	32"(0.81m)	36"(0.91m)	4C.C.W
3	36"(0.91m)	42"(1.07m)	0(PRESET)
4	42"(1.07m)	48"(1.22m)	5C.C.W
5	48"(1.22m)	54"(1.22m)	10C.C.W
6	54"(1.37m)	58"(1.47m)	15C.C.W

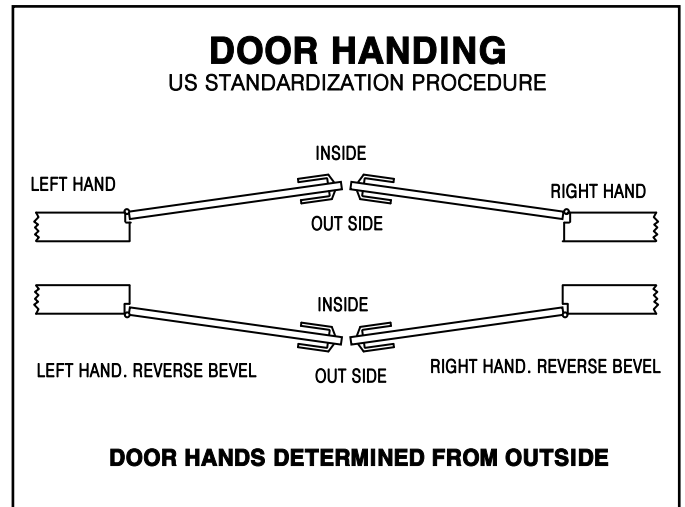

C.W. = CLOCKWISE
C.C.W = COUNTER CLOCKWISE

PLEASE NOTE
TURNS REQUIRED ARE APPROXIMATE
BECAUSE OF VARIOUS DOOR CONDITIONS
AND LOCATIONS. YOU MAY HAVE TO
FURTHER ADJUST SPRING TENSION TO
SUIT YOUR REQUIREMENTS.

**IT IS IMPORTANT TO CAREFULLY
FOLLOW ALL INSTALLATION AND
MOUNTING INSTRUCTIONS WHEN
INSTALLING ANY DOOR CLOSER.**

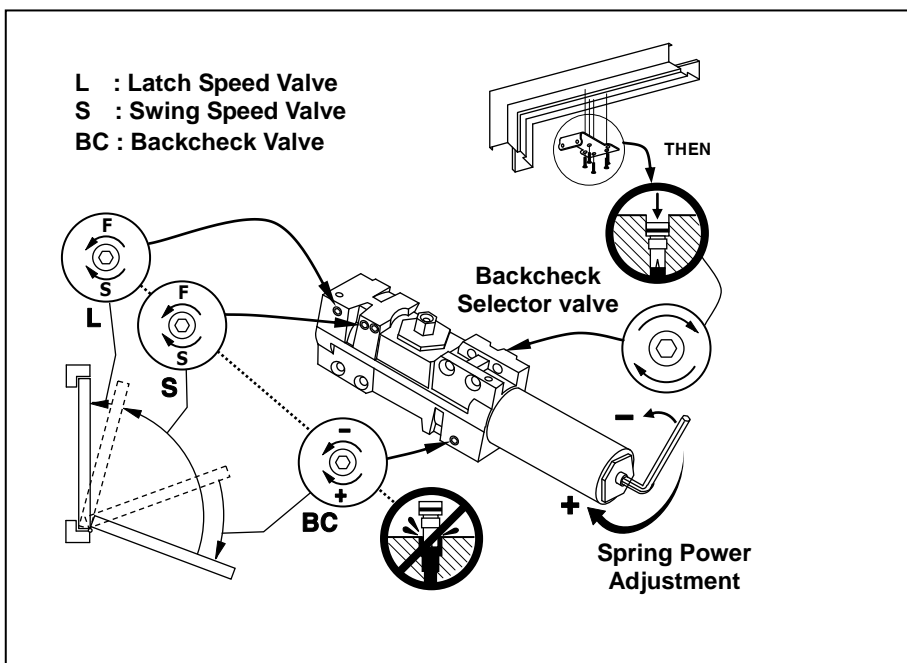

- Screw Pack**
- (a) Machine x4
 - (b) Self-tapping x4
 - (c) Machine x4
 - (d) Self-tapping x4
 - (e) Machine x1
 - (f) Self-tapping x1
 - (g) x2
 - (h) x1
 - (i) x1
 - (j) x2
 - (k) x1
 - (l) 4mm L wrench x1
 - (m) 2.5mm L wrench x1

STANDARD INSTALLATION CLOSER MOUNTED ON DOOR ON PULL SIDE

DOOR OPENING: 120°

LEFT HAND DOOR shown. RIGHT HAND DOOR is opposite.

2 Holes for #14
All-Purpose or 1/4-20
(M6×1.0) Machine
Screws.

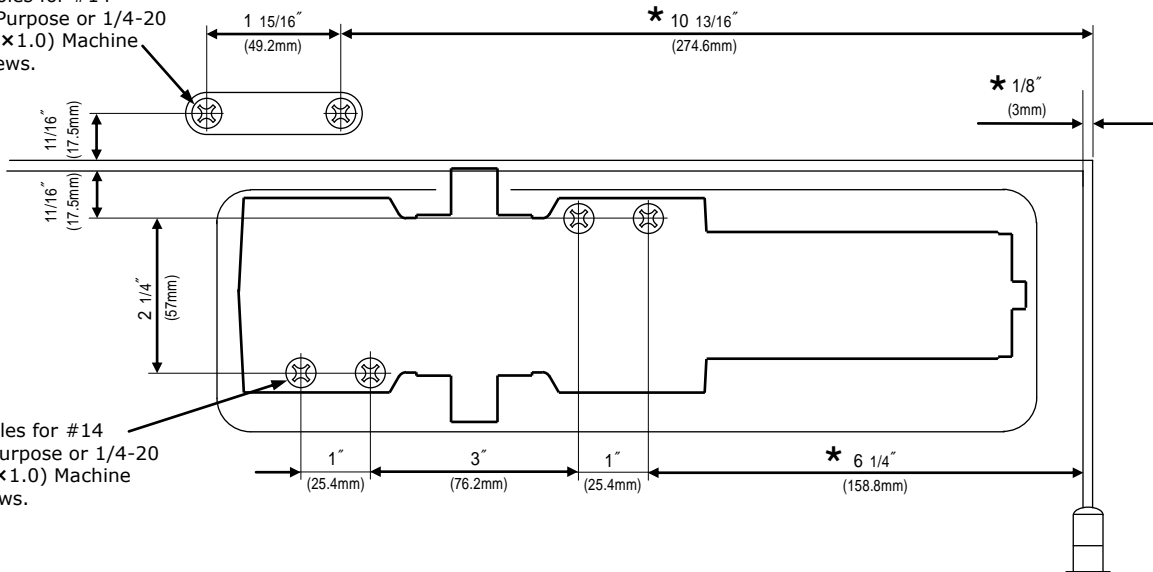

4 Holes for #14
All-Purpose or 1/4-20
(M6×1.0) Machine
Screws.

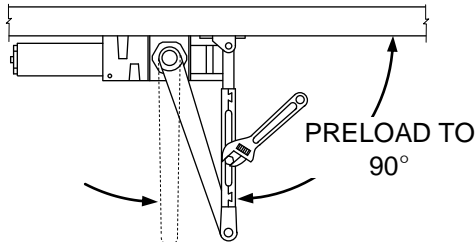
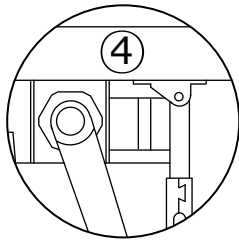

1. Adjust spring power to match door width as indicated by chart on page 1.
 2. Mount closer on door as dimensions shown. Tube end toward hinge. If pivots are used, locate closer and shoe from CENTERLINE OF PIVOT.
 3. Place main arm on top of shaft, 100° to closer body, insert arm screw into top of shaft and tighten.
 4. Attach shoe to frame as shown. (If more latching power is required, rotate shoe 180° from position shown in fig. 4)
 5. Open door and insert rod in forearm.
 6. Rotate forearm away from hinge edge of door until forearm is 90° to frame face, insert forearm, set screw and tighten.
- (IF HOLD OPEN ARM IS USED, THE NUT IS ON THE TOP FOR RH DOOR AND BOTTOM FOR LH DOOR)

REGULATION:

A 'Normal' closing time from 90° open position to door stop position is 4-6 secs, evenly divided between main swing speed and latch swing speed. Use socket key (furnished) to adjust speed. To slow main speed of door, turn regulating screw nearest shaft clockwise. To slow latch speed, turn regulating screw nearest latch clockwise.

BACKCHECK

To increase BACKCHECK force, turn regulating screw nearest hinge clockwise. DO NOT USE ABRUPT BACKCHECK OR EXPECT DOOR CLOSER TO ACT AS A DOOR STOP.

COVER

Place insert in proper cutout, then push cover against door. Tighten both cover screw securely.

HOLD OPEN ADJUSTMENT (when hold open arm is used)

Loose adjusting nut, open door to desired hold open position and tighten nut. Do not permit door to swing beyond hold open setting.

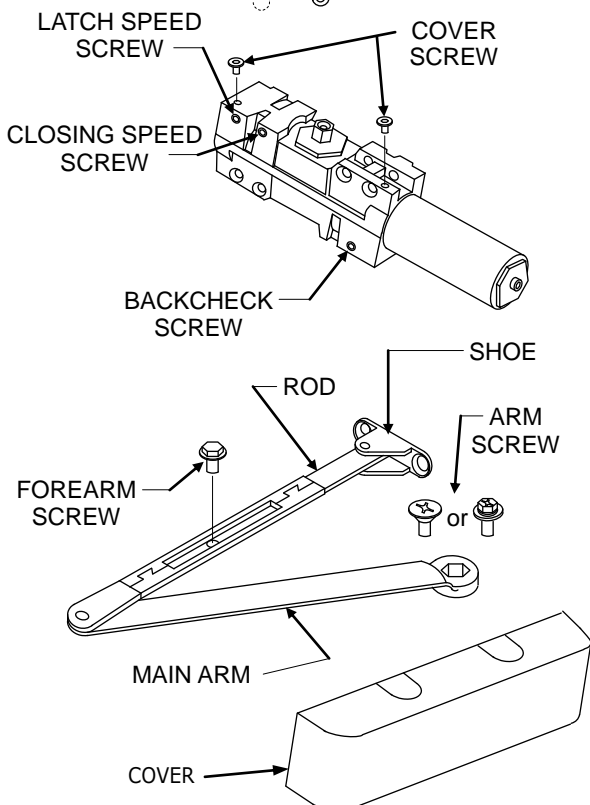

TOP JAMB INSTALLATION CLOSER MOUNTED TOP JAMB ON PUSH SIDE OF DOOR

DOOR OPENING: 120°

RIGHT HAND DOOR shown. LEFT HAND DOOR is opposite.

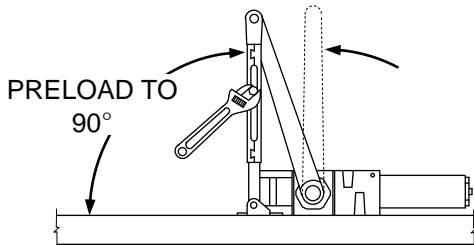
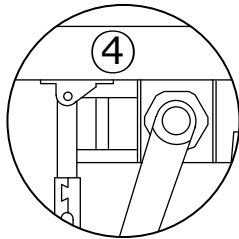
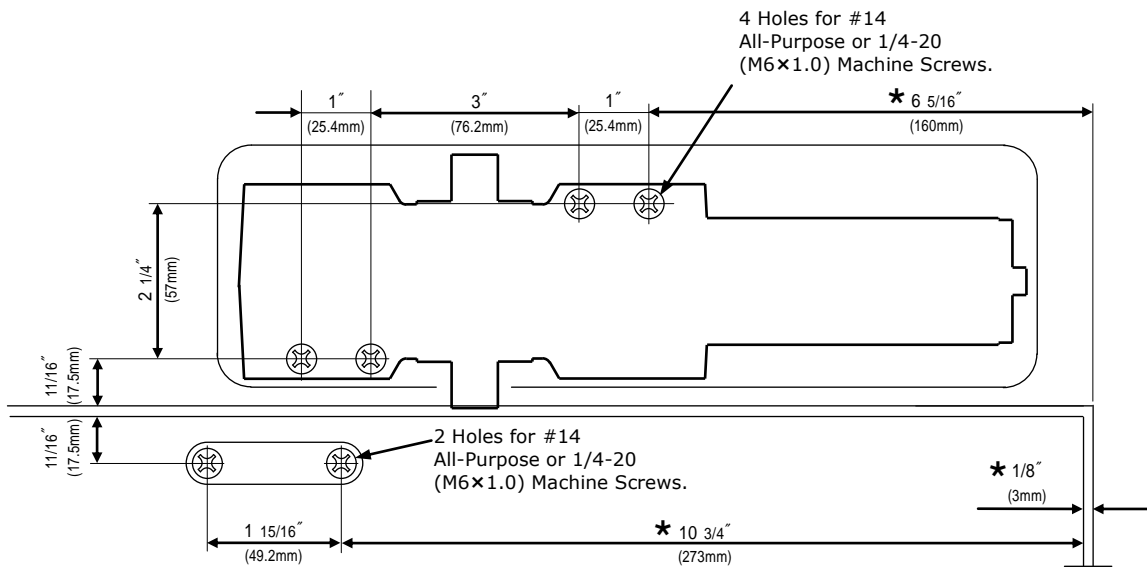

1. Adjust spring power to match door width as indicated by chart on page 1.
 2. Mount closer on frame as dimensions shown. Tube end toward hinge. If pivots are used, locate closer and shoe from CENTERLINE OF PIVOT.
 - (* For offset pivots, please increase the marked dimensions by 1/8")**
 3. Place main arm on top of shaft, 100° to closer body, insert arm screw into top of shaft and tighten.
 4. Attach shoe to frame as shown. (If more latching power is required, rotate shoe 180° from position shown in fig. 4)
 5. Open door and insert rod in forearm.
 6. Rotate forearm away from hinge edge of door until forearm is 90° to frame face, insert forearm, set screw and tighten.
- (IF HOLD OPEN ARM IS USED, THE NUT IS ON THE TOP FOR RH DOOR AND BOTTOM FOR LH DOOR)

REGULATION:

A 'Normal' closing time from 90° open position to door stop position is 4-6 secs, evenly divided between main swing speed and latch swing speed. Use socket key (furnished) to adjust speed. To slow main speed of door, turn regulating screw nearest shaft clockwise. To slow latch speed, turn regulating screw nearest latch clockwise.

BACKCHECK

To increase BACKCHECK force, turn regulating screw nearest hinge clockwise. DO NOT USE ABRUPT BACKCHECK OR EXPECT DOOR CLOSER TO ACT AS A DOOR STOP.

COVER

Place insert in proper cutout, then push cover against door. Tighten both cover screw securely.

HOLD OPEN ADJUSTMENT (when hold open arm is used)

Loose adjusting nut, open door to desired hold open position and tighten nut.

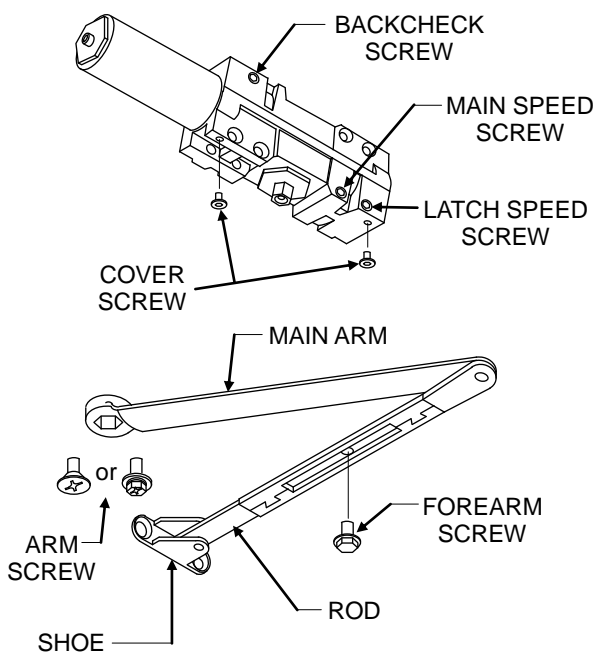

PARALLEL ARM INSTALLATION CLOSER MOUNTED ON DOOR ON PUSH SIDE

DOOR OPENING: 180°

RIGHT HAND DOOR shown. LEFT HAND DOOR is opposite.

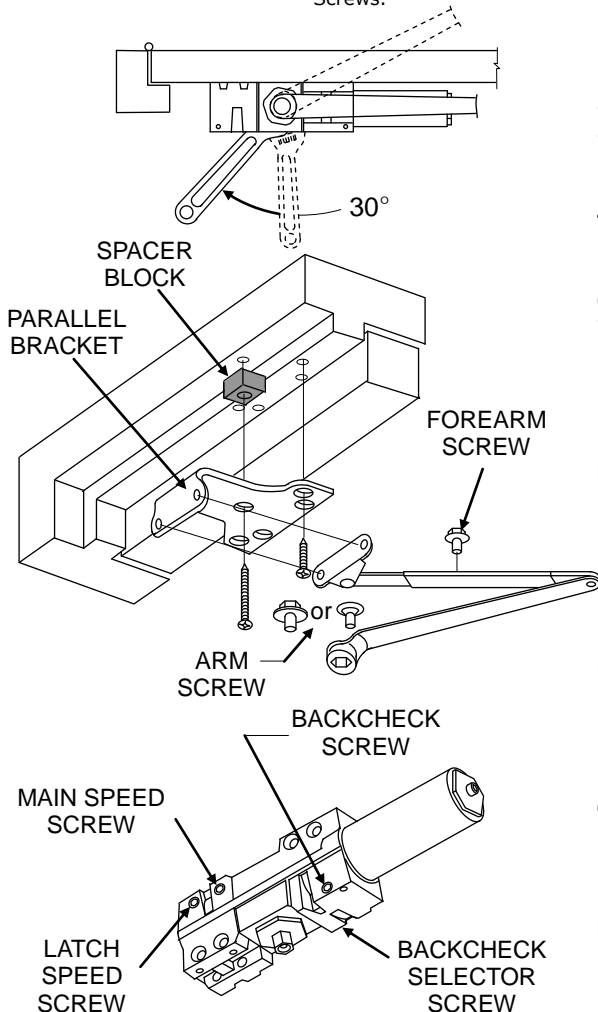
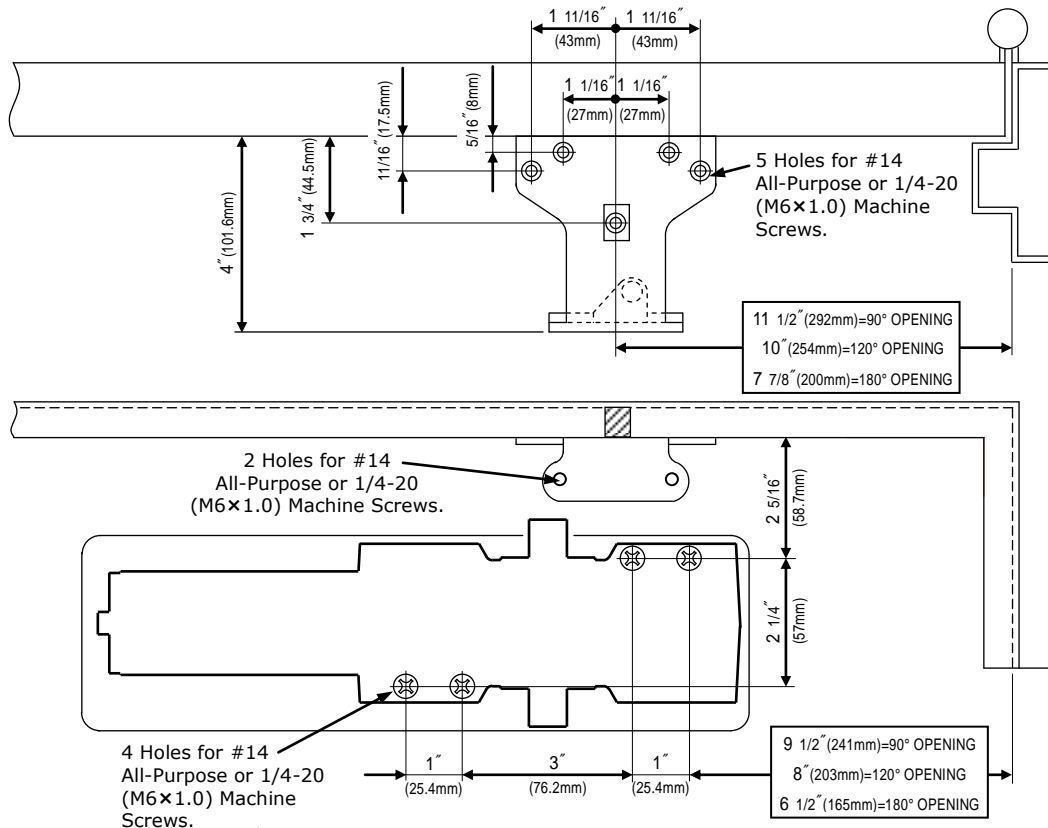

1. Before installation, turn BACKCHECK selector valve (found on the opposite side of closer from backcheck screw side) ALL THE WAY IN CLOCKWISE.
2. Adjust spring power to match door width as indicated by chart on page 1.
3. Mount closer on door at dimensions shown with tube end toward latch edge of door. If pivots are used, locate closer and parallel bracket from CENTERLINE OF PIVOT.
4. Place open end wrench on bottom shaft and turn toward hinge jamb about 30° and then place main arm on top shaft, insert arm screw into top of shaft and tighten.
5. Attach parallel bracket on frame at dimensions shown.
6. Attach rod and shoe to parallel bracket as shown.
7. Insert rod in forearm, and rotate main arm parallel to door. Then insert forearm set screw and tighten.
(IF HOLD OPEN ARM IS USED, THE NUT IS ON THE TOP FOR RH DOOR AND BOTTOM FOR LH DOOR)

REGULATION:

A 'Normal' closing time from 90° open position to door stop position is 4-6 secs, evenly divided between main swing speed and latch swing speed. Use socket key (furnished) to adjust speed. To slow main speed of door, turn regulating screw nearest shaft clockwise. To slow latch speed, turn regulating screw nearest hinge clockwise.

BACKCHECK

To increase BACKCHECK force, turn regulating screw nearest latch clockwise. DO NOT USE ABRUPT BACKCHECK OR EXPECT DOOR CLOSER TO ACT AS A DOOR STOP.

COVER

Place insert in proper cutout, then push cover against door. Tighten both cover screw securely.

HOLD OPEN ADJUSTMENT (when hold open arm is used)

Loose adjusting nut, open door to desired hold open position and tighten nut. Do not permit door to swing beyond hold open setting.